

H o m e T h e a t r e S e r i e s



u s e r m a n u a l



H o m e T h e a t r e S e r i e s

In selecting ATC you have chosen an example of the finest audio engineering available.

Since its very beginning ATC has kept steadfastly to its founders' aim of building, mostly by hand,

loudspeakers which employ the most effective of modern engineering principles.

That has meant striving to make loudspeakers as near perfection as it is possible to make them.

In order to get the very best from ATC equipment careful and thoughtful installation is essential,

so please read the manual fully to understand your ATC monitor

and realize the very best performance it has to offer.

Please contact ATC with any questions or issues that arise during installation or use

and we will do our very best to help.

ATC (Acoustic Transducer Company) was founded in London in 1974 by Australian Billy Woodman who still heads

the company today. An enthusiastic jazz pianist and engineer he was naturally drawn to loudspeaker design.

After working for ROLA in Melbourne Billy, in 1970, travelled to England and worked in R&D at Goodmans in

Wembley (the training ground of many well-known British loudspeaker engineers) before starting ATC.

The philosophy upon which ATC began the development of its studio products is a simple one: that at their best,

hi-fi loudspeakers are detailed and accurate but limited by dynamic range,

whilst professional monitor loudspeakers have plenty of dynamic range but lack the clarity and accuracy.

ATC bridged this gap by developing, in house, unique drive units of exceptionally low coloration performance and

large dynamic range. There is therefore no differentiation technically between an ATC hi-fi product and professional

monitor other than the way it is packaged. A high fidelity loudspeaker is a high fidelity loudspeaker whether it is

for home or work.

The Home Theatre Series (HTS) from ATC offers unrivalled levels of performance from an install loudspeaker and

unlike many alternatives is capable of delivering both low distortion and high dynamic range in a discrete, easily

installed package. The range is suitable for both full surround systems as well as stereo listening.

In order to obtain the best performance from the Home Theatre Series they can be partnered with ATC's

own range of electronics.

From modest beginnings ATC has grown to become one of the very few manufacturers successful across both

domestic and professional audio. By selecting ATC you join a group of music lovers, professional audio engineers,

educators, studios and musicians across the world that understand the value of the engineering that goes into every

ATC product.

1 : Safety Warnings

1. Read instructions – all the safety and operating instructions should be read before the appliance is operated.
2. Retain these instructions – the safety and operating instructions should be retained for future reference.
3. Follow instructions – all operating and other instructions should be followed.
4. Water and moisture - the appliance should not be exposed to dripping or splashing and no objects such as vases, should be placed on the appliance.
5. Heat – the appliance should be situated away from heat sources such as radiators, stoves or other appliances that produce heat.
6. Cleaning – the appliance should be cleaned only as recommended by the manufacturer.
7. Servicing – the user should not attempt to service the appliance beyond those measures described in the operating instructions. All other servicing should be referred to qualified service personnel.

2 : Unpacking & Handling

1. All loudspeakers in the HTS range are heavy items and should be handled with care. Unpacking should be carried out by two people either on the floor or a large low table, with adequate open space around the carton, preferably close to their final position.
2. Open the carton and remove all loose items, leaving the packing foam in place.
3. Up-end the carton so the open end is facing down.
4. Lift the carton off the contents (speaker & foam 'end-caps').
5. Lift the upper foam end cap off.
6. Lift each loudspeaker out of the foam end cap.

3 : Monitor Placement

The subjective performance of any loudspeaker will be influenced by the acoustic character of the room in which it is used and its position within the room. A mixture of carpets, curtains and soft furnishings will help ensure that the middle and high frequencies are reasonably well controlled.

When a loudspeaker is wall mounted a proportion of the low frequency energy which is normally radiated towards the rear is sent forward, resulting in a boost to lower frequencies. In most cases the additional bass energy can overwhelm the system and degrade performance. The HTS range of loudspeakers address this issue through carefully optimised crossovers designed to compensate for the wall loading effect.

For the best performance the loudspeakers should be mounted directly on to the wall allowing at least 1.5m between the loudspeaker and any side walls.

Stereo Speaker Placement

For stereo listening, loudspeakers should be positioned so they form an equilateral triangle with the listening position (See **Fig. 1**). The loudspeaker height requirements are explained later in this section.

Centre Speaker Placement

The positioning constraints on a centre channel loudspeaker are always influenced by the type and location of the associated screen. However, the basic parameters that influence the subjective performance of any loudspeaker in a listening room as described above, should be taken in to account.

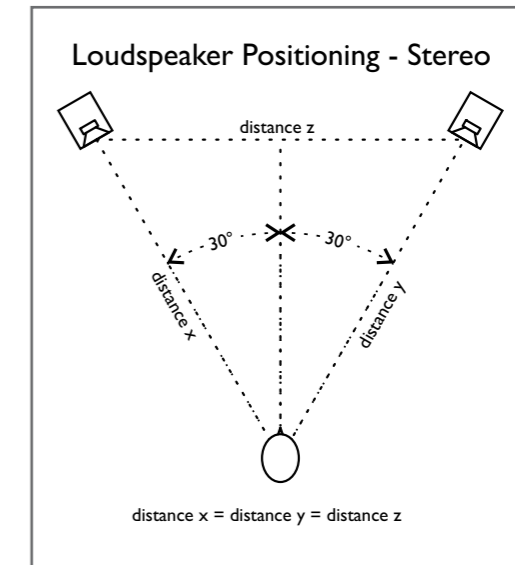

Fig. 1

The HTS7C, HTS11C and HTS40 (horizontal configuration) are intended to be positioned either just below or just above the screen.

While every ATC centre channel speaker is effectively magnetically shielded, the extreme sensitivity of some CRT tubes to residual levels of magnetic flux may mean that, in rare cases, ATC centre channel speakers are not appropriate. Adjusting the relative position of the centre speaker and the CRT can reduce magnetic interference but should your screen suffer intractable picture distortion caused by the proximity of a centre speaker contact your dealer or installer for advice.

3 : Monitor Placement (contd.)

Surround Speaker Placement

While each loudspeaker in an AV system should be located appropriately in its immediate acoustic environment, correct positioning will offer the best chance of programme material being heard as intended. The basic guidelines for positioning the full bandwidth speakers of a 5.1 or 7.1 system are illustrated in Fig 2. The elements of an AV system should follow this positioning guide as closely as possible although there is some latitude for compromise in the speaker to listener distance of a domestic installation as AV coders/processors provide facilities to adjust the delay time of all or some speaker channels.

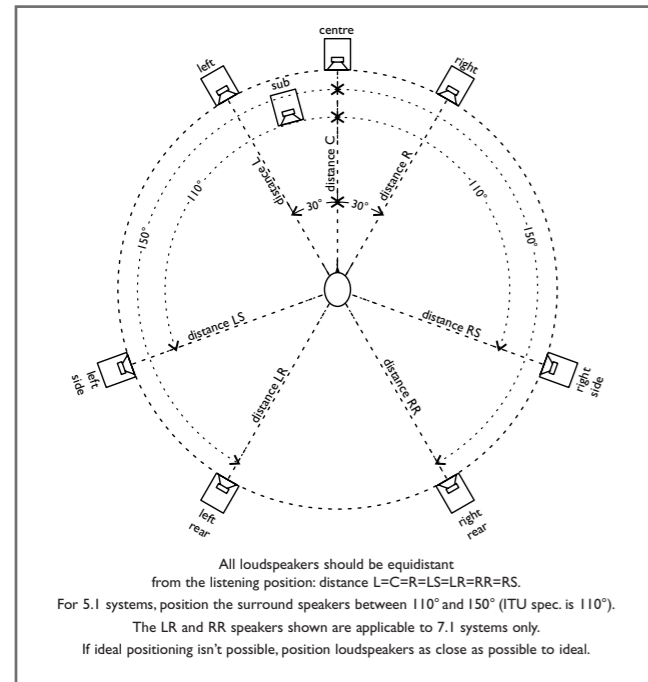

Fig. 2

Ideal Full Bandwidth Speaker Positioning of 5.1 and 7.1 systems

Acoustic Axis and Height Positioning

The loudspeakers should be mounted with the acoustic axis at or slightly above ear height. The acoustic axis of each loudspeaker is shown opposite:

4 : Connection

Each HTS loudspeaker is equipped with a “single pair” connection panel. The terminals can accommodate either stripped bare cable ends, 4mm banana plugs or spade terminals. Always use a good quality speaker cable with minimum cross sectional area per conductor (minimum 79 strand). For cable runs longer than 5 metres use a significantly heavier gauge cable. Consult your dealer or consultant for specific cable recommendations.

Ensure that the positive and negative terminals on each connection panel are connected to the corresponding positive and negative terminals on the amplifier. A lack of bass output and very wide unstable stereo image is most likely caused by the left and right loudspeakers being connected out of phase. If the system displays these characteristics, please check the polarity of the wiring.

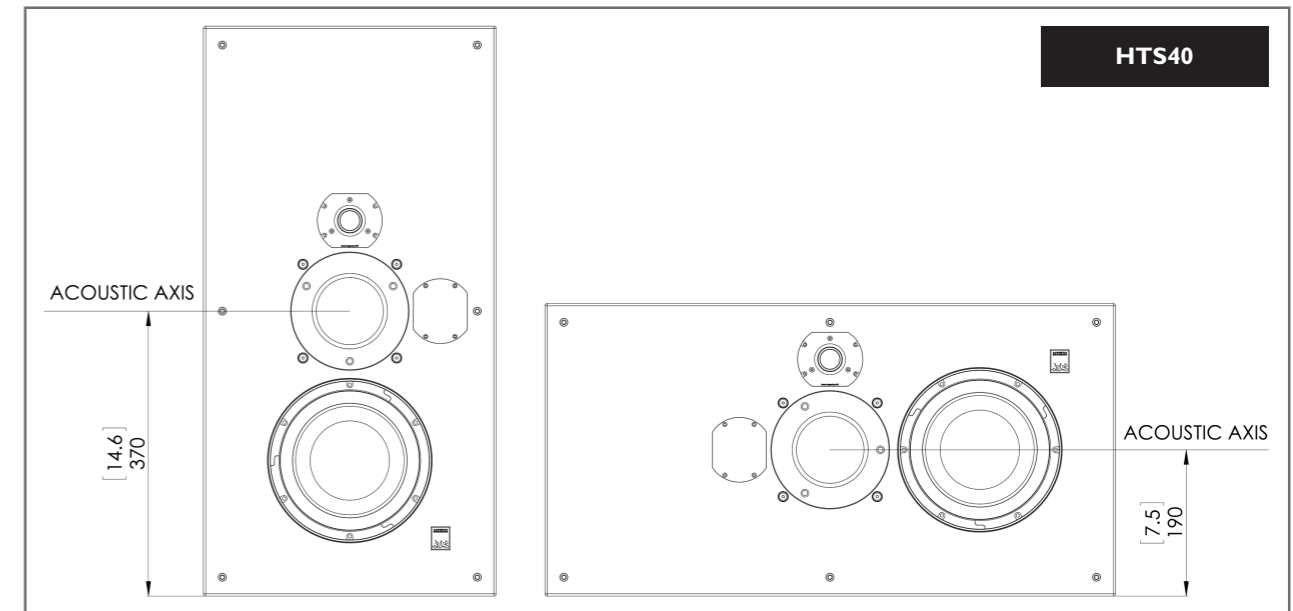
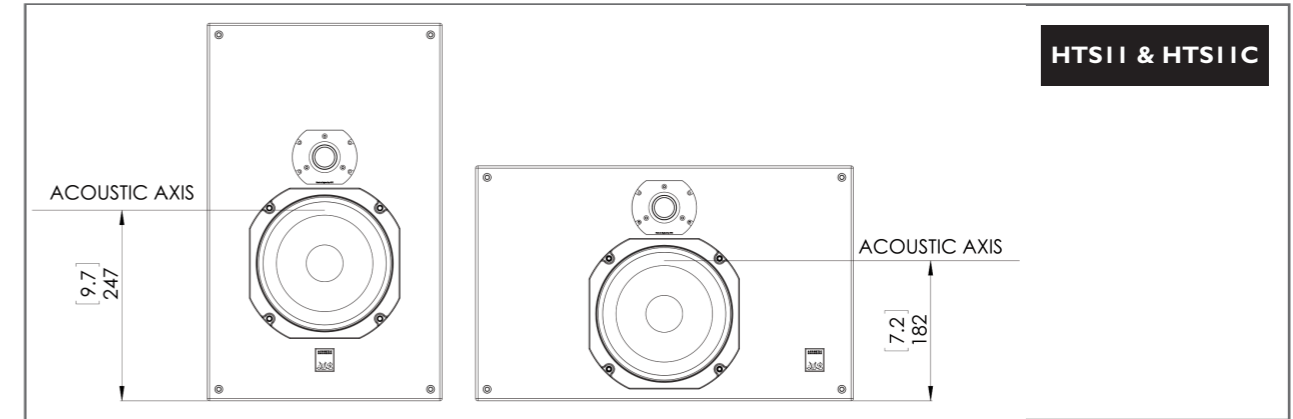
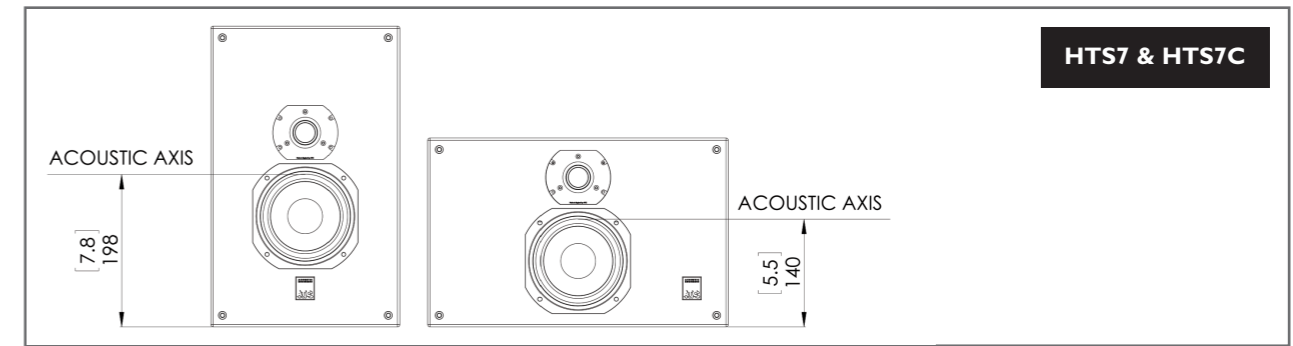

5 : Wall Mounting

Each HTS loudspeaker is equipped with “keyhole” fixing plates as shown in **Fig 3**. A soft/compressible 90 degree gasket is positioned on each corner to ensure positive, vibration free contact with the wall.

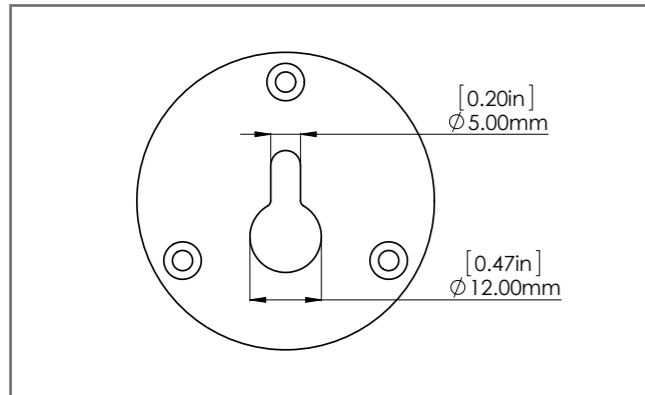

Fig. 3
“Keyhole” fixing for wall mounting

Use the template provided to mark the appropriate fixing locations on the wall. All HTS loudspeakers are heavy, therefore it is imperative that the wall construction is appropriate and suitable fixings capable of holding the weight of the loudspeaker plus a safety factor of no less than 10:1 are used.

The weights of each loudspeaker are as follows:

| | |
|---------------|-----------------|
| HTS7 | 8kgs (17.6lbs) |
| HTS7C | 8kgs (17.6lbs) |
| HTS11 | 11kgs (24.3lbs) |
| HTS11C | 11kgs (24.3lbs) |
| HTS40 | 23kgs (50.7lbs) |

6 : Amplification

The choice of partnering amplifier for the monitors will have significant influence on the performance of the system. Consider the following when selecting the amplifier:

- With any passive loudspeaker there is a trade off between low frequency extension and sensitivity. These monitor's extended low frequency response means the sensitivity is relatively low. It is therefore advisable to select a power amplifier of relatively high power output capabilities. Typically, best performance comes with use of amplifiers capable of >150W continuous into 8 ohms.
- Use of an underpowered amplifier will result in the premature distortion of the system and increased risk of damage due to voice coil overheating
- Valve or solid state amplifiers with high output impedances should be auditioned carefully, to establish that their characteristic reduced damping factor at low frequencies is acceptable.

7 : Listening

The ear and brain tend to interpret distorted sound as loudness and thus underestimate the actual level of undistorted sound. The HTS range of loudspeakers, like all ATC monitors, demonstrate very much lower levels of distortion than conventional systems of a similar size. It is therefore advisable to begin listening at an artificially low level and carefully increase the volume. It is also possible for the loudspeakers to produce sufficient sound pressure levels for your ears themselves to become a source of distortion and make the sound appear harsh. Any audible distortion indicates that either the system or your ears are being overloaded and that volumes should be reduced.

8 : Care & Maintenance

High technology material finishes are used in this product. The surfaces are durable and with a little care can be kept as good as new even under conditions of heavy use. Normally, a dry duster will be all that is required to keep the finishes clean. Heavy soiling can be cleaned using a cloth slightly moistened with a non-abrasive household cleaner.

There are no components within the speakers that can be considered expendable, or that would benefit from regular maintenance. There is no requirement for any kind of routine service work and there is no schedule for preventative maintenance.

There are no user-replaceable parts within the speaker and, in the unfortunate event of any malfunction, repair should be referred to either the supplying dealer or consultant, the relevant importer, or ATC.

ATC has every confidence in the quality of each product that it manufactures.



9 : Specifications

HTS7 / HTS7C*

Drivers : HF ATC 25mm Neo Soft Dome, Mid/LF ATC 125mm SC

Matched Response : +/- 0.5dB

Frequency Response (half space radiation -6dB) : 44Hz-22kHz

Dispersion : ±80° Coherent Horizontal, ±10° Coherent Vertical

Sensitivity : 84dB @ 1W @ 1metre **Max SPL :** 103dB

Recommended Power Amplifier : 75 to 300 Watts

Nominal Impedance : 8 Ohm **Crossover Frequency :** 2.5kHz

Connectors : Binding Posts/4mm Plugs

Cabinet Dimensions (HxWxD):

HTS7 390x245x125mm, **HTS7C** 245x390x125mm. Grill adds 12mm to depth

Weight : 8kg

HTS11 / HTS11C*

Drivers : HF ATC 25mm Neo Soft Dome, Mid/LF ATC 150mm SC

Matched Response : +/- 0.5dB

Frequency Response (half space radiation -6dB) : 40Hz-22kHz

Dispersion : ±80° Coherent Horizontal, ±10° Coherent Vertical

Sensitivity : 85dB @ 1W @ 1metre **Max SPL :** 108dB

Recommended Power Amplifier : 75 to 300 Watts

Nominal Impedance : 8 Ohm **Crossover Frequency :** 2.2kHz

Connectors : Binding Posts/4mm Plugs

Cabinet Dimensions (HxWxD):

HTS11 490x305x125mm, **HTS11C** 305x490x125mm. Grill adds 12mm to depth

Weight : 11kg

HTS40 / HTS40C*

Drivers : HF ATC 25mm Neo Soft Dome, Mid ATC 75mm Soft Dome, LF ATC 164mm SC

Matched Response : +/- 0.5dB

Frequency Response (half space radiation -6dB) : 32Hz-22kHz

Dispersion : ±80° Coherent Horizontal, ±10° Coherent Vertical

Sensitivity : 85dB @ 1W @ 1metre **Max SPL :** 112dB

Recommended Power Amplifier : 75 to 300 Watts

Nominal Impedance : 8 Ohm **Crossover Frequencies :** 380Hz & 3.5kHz

Connectors : Binding Posts/4mm Plugs

Cabinet Dimensions (HxWxD):

HTS40 740x380x154mm, **HTS40C** 380x740x154mm. Grill adds 12mm to depth

Weight : 23kg

* 'Left/Right' and 'Centre' versions each have equal performance and are freely interchangeable. Choice of speaker orientation/configuration should be based on fit and visual appearance alone.

I 0 : Warranty & Contact

All ATC products are guaranteed against any defect in materials or workmanship for a period of two years from the date of purchase.

Within this period we will supply replacement parts free of charge provided that the failure was not caused by misuse, accident or negligence.

Purchasers who complete and return the Warranty Card will have their warranty period extended up to a period of six years from the date of purchase.

This guarantee does not limit statutory rights.



Loudspeaker Technology Ltd Gypsy Lane, Aston Down, Stroud, Gloucestershire GL6 8HR United Kingdom

Telephone +44 (0)1285 760561 **Fax** +44 (0)1285 760683

Email: info@atc.gb.net **Website:** www.atcloudspeakers.co.uk

Acoustic Transducer Company is the trading name and  is the registered trade mark of Loudspeaker Technology Ltd.